

INDUSTRIAL DIESEL ENGINE

KUBOTA SUPER MINI SERIES (2-cylinder)

# Z602-E4B

## RATED POWER

- 10.8kW@3200rpm
- 12.5kW@3600rpm

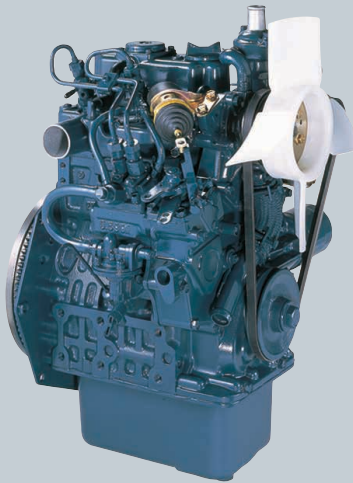

Photograph may show non-standard equipment.

## PERFORMANCE CURVE

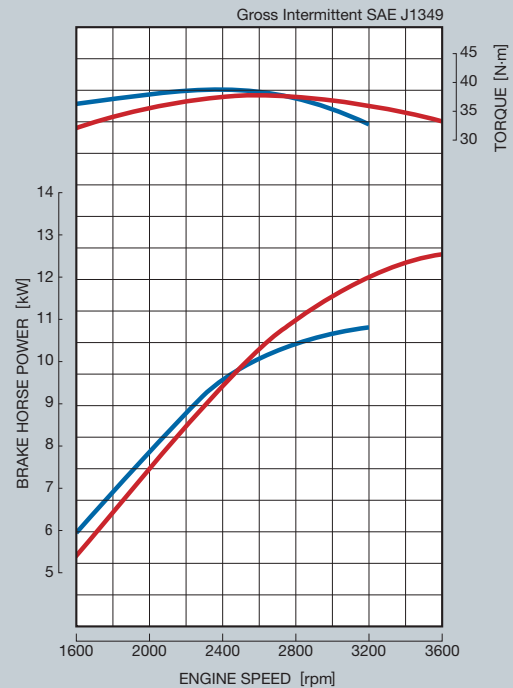

## FEATURES and BENEFITS

### Emissions

Kubota Super Mini Series, the most compact multi-cylinder liquid cooled industrial diesel engines, complies with EPA Tier 4 emissions regulations. These are the most stringent emissions regulations in the world in this class. Kubota engine less than 19kW meets emission standards over the NRTC and also meets the NTE requirements.

### Clean and Quiet Power

Kubota's original E-TVCS (Three Vortex Combustion System) has been further improved for better emissions.

### Durable Power

The Kubota Z602 engine is a high power density engine that delivers the highest output in a 2-cylinder configuration. By expanding the bore and stroke, Kubota increased engine displacement, while maintaining the same footprint as the Z482 engine. By adopting an extended shallow oil pan, the engine height is lower than the Z482 engine, providing a compact engine package.

The cooling water passages between the cylinder bores, using Kubota's original casting technology as a countermeasure against heat load of high power density, provides both superior endurance and reliable engine characteristics.

This engine offers a seamless transition from Tier 2 to Tier 4 by totally maintaining the same performance and physical characteristics of the previous Tier 2 engines.

# KUBOTA SUPER MINI SERIES Z602-E4B

## GENERAL SPECIFICATION

Model		Z602-E4B	
Emission Regulation		Tier 4	
Type		Vertical 4-cycle Liquid Cooled Diesel	
Number of Cylinders		2	
Bore	mm (in)	72 (2.83)	
Stroke	mm (in)	73.6 (2.90)	
Displacement	L (cu.in)	0.599 (36.55)	
Combustion System		IDI	
Intake System		Naturally Aspirated	
Maximum Speed	rpm	3200	3600
Output: Gross Intermittent ( Industrial Use )	kW	10.8	12.5
	hp	14.5	16.8
Direction of Rotation		Counterclockwise Viewed on Flywheel	
Oil Pan Capacity	L (gal)	2.5 (0.66)	
Starter Capacity	V-kW	12-1.0	
Alternator Capacity	V-A	12-40	
Output: Stand-by ( Generator Use )	kW	11.0	
	hp	14.7	
Output: Continuous ( Generator Use )	kW	15.2	
	hp	13.5	
Length	mm (in)	384.6 (15.14)	
Width	mm (in)	420.5 (16.6)	
Height (1)	mm (in)	544.1 (21.42)	
Height (2)	mm (in)	204.0 (8.03)	
Dry Weight	kg (lb)	60.0 (132.3)	

\*Specification is subject to change without notice.  
 \*Output: Gross Intermittent SAE J1995  
 \*Output: Stand-by, Continuous ISO 3046  
 \*Dry weight is according to Kubota's standard specification.  
 When specification varies, the weight will vary accordingly.

## DIMENSIONS

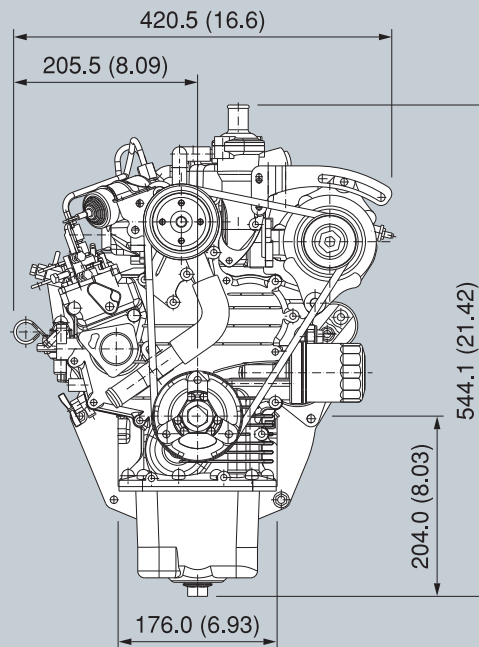
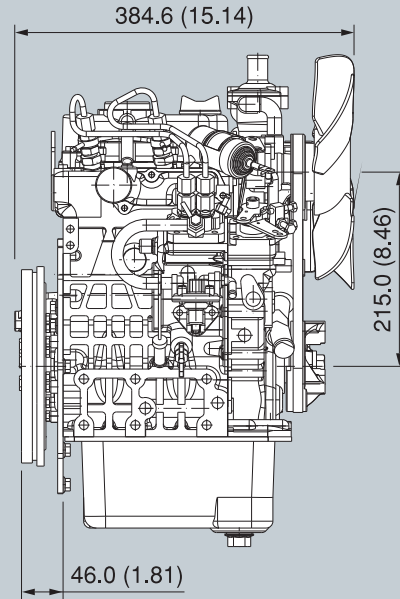

# For Earth, For Life



**KUBOTA ENGINE AMERICA**  
 505 Schelter Road Lincolnshire, IL 60069  
 Phone: 847-955-2500 Fax: 847-955-2501  
 www.kubotaengine.com

**KUBOTA CANADA, LTD**  
 5900 14th Avenue, Markham, Ontario L3S 4K4  
 Phone: 905-294-7477 Fax: 905-294-1554