

# TCD 2011

The Construction Equipment Engine. 23.5–74.9 kW | 32–100 hp at 1600–2800 rpm



The engine company.



# Your benefits

- Compact dimensions. Takes up less space and reduces installation costs.
- The 2011 model series offers an outstanding power-to-weight ratio.
- Low exhaust emissions for a clean environment. Compliance with 2004/26/EU level III A and EPA TIER III for mobile equipment.
- High reliability combined with long maintenance intervals and low wear.
- Low noise emission eliminates the need for costly noise-reducing soundproofing measures.

# Characteristics

Compact dimensions | Naturally-aspirated 2-, 3- and 4-cylinder in-line engines | Turbocharging also for 4-cylinder engines plus turbocharging and charge air cooling | Power take-offs for driving hydraulic pumps up to 28 kW/2800 rpm | All service points located on one side of the engine

## TIER III/level III A performance for mobile working machines <sup>1)</sup>

Engine model		D 2011 L2	D 2011 L3	D 2011 L4	TD 2011 L4	TCD 2011 L4
Number of cylinders		2	3	4	4	4
Bore/stroke	mm	94/112	94/112	96/125	96/125	96/125
	inch	3.7/4.4	3.7/4.4	3.8/5.0	3.8/5.0	3.8/5.0
Swept volume	l   cu inch	1.55   95	2.33   142	3.62   221	3.62   221	3.62   221
Compression ratio		1 : 19	1 : 19	1 : 19	1 : 18	1 : 19
Max. rated speed	rpm	2800	2800	2600	2600	2600
Mean piston speed	m/s   ft/sec	10.5   34.4	10.5   34.4	10.8   35.4	10.8   35.4	10.8   35.4

## Performance for mobile working machines <sup>1)</sup>

Output according to ISO 14396	kW   hp	23.5   32	36.5   49	50   67	68   91	74.9   100
At engine speed	rpm	2800	2800	2600	2600	2600
At mean, effective pressure	bar   lb/inch	6.5   94	6.7   97	6.4   93	8.7   126	9.6   139
Max. torque	Nm   lb/ft	93   69	140   103	200   148	280   207	350   258
At engine speed	rpm	1700	1700	1700	1600	1600
Minimum idle speed	rpm	900	900	900	900	900
Specific fuel consumption <sup>2)</sup>	g/kWh   lb/hp-hr	225   0.37	225   0.37	225   0.37	220   0.36	215   0.35
Weight according to DIN 70020, Part 7A <sup>3)</sup>	kg   lb	169   373	210   463	260   573	259   571	259   571

## Dimensions

in mm   inch	A	B	C
<b>D 2011 L2</b>	408   16.1	451   17.8	683   26.9
<b>D 2011 L3</b>	599   23.6	451   17.8	678   26.9
<b>D 2011 L4</b>	710   28.0	451   17.8	713   28.1
<b>TD 2011 L4</b>	710   28.0	495   19.5	713   28.1
<b>TCD 2011 L4</b>	710   28.0	495   19.5	713   28.1

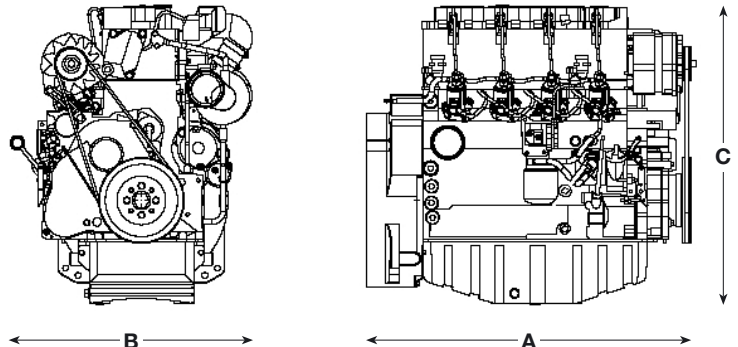

1) To ISO 14396.

2) At best point. Specific fuel consumption with reference to diesel fuel with a density of 0.835 kg/dm<sup>3</sup> at 15 °C (6.96 lb/US gallon at 60 °F).

3) Including flywheel and SAE housing, but without starter motor, alternator, radiator, fan and operating fluids.

The values specified in this datasheet are for information purposes only and are not binding.

The information given in the quotation is decisive.