



# 1011. The engine for construction equipment.



11 - 55.5 kW at 1500 - 3000 min<sup>-1</sup>



## Engines with integrated cooling system

### These are the characteristics of the 1011:

- 2-, 3- and 4-cylinder naturally aspirated in-line engines.
- 4-cylinder engine also turbocharged.
- Integrated cooling system (engine is supplied complete with cooler)
- Cooling and lubrication with oil.
- Acoustically optimized crankcase.
- All service points on one engine side.
- Compact engine design.
- Worldwide service network with more than 3,000 service bases.

### These are the benefits for you:

- ▶ Low noise emission, no expensive insulation measures for noise reduction.
- ▶ Long maintenance intervals: 1,000 h oil change intervals and low fuel consumption allow savings in operating costs.
- ▶ Low installation costs.
- ▶ Service- and user-friendly.
- ▶ Cooling and lubrication with oil avoid corrosion and cavitation. High reliability, long service life and less wear parts.

## Engine description

Type of cooling:	Integrated oil cooling
Crankcase:	Grey cast iron
Crankcase breather :	Closed-circuit breather
Cylinder head:	Block-type cast iron cylinder head
Valve arrangement/ Timing:	Overhead valves in cylinder head, one inlet and one exhaust valve per cylinder, actuated from belt-driven camshaft via tappets, push rods and rocker arms
Piston:	Three-ring piston, two compression rings and one oil scraper ring
Piston cooling:	Oil-cooled with spray nozzles
Connecting rod:	Drop-forged steel rod
Crankshaft and big-end bearings:	Ready-to-install plain bearings
Crankshaft:	Nodular cast iron
Camshaft:	Steel shaft in bi-metal bearings
Lubrication system:	Forced-feed circulation lubrication with rotary pump which feeds both lubricating and cooling systems (and cab heating if fitted)
Lube oil cooler:	Integrated in engine, of light metal
Lube oil filter:	Paper-type micro-filter as replaceable-cartridge full flow filter
Injection pump/ governor:	Single injection pumps with mechanical centrifugal governor
Fuel lift pump:	Serviceable, with integrated strainer
Injection nozzle:	Five-hole nozzle
Fuel filter:	Replaceable cartridge
Alternator:	Three-phase alternator, 14 V; 55 A (Standard)
Starter motor:	2,2 kW; 12 V
Heating system:	Optional connection for cab heating
Options:	Intake manifold connections, exhaust manifold connections, hydraulic pumps, engine mounts rigid and flexible, oil pans, dipsticks, SAE 3/4/5/6 flywheel housings, alternators 12 and 24 V, oil filter positions horizontal and vertical, oil filler neck on side of crankcase or in cylinder head cover

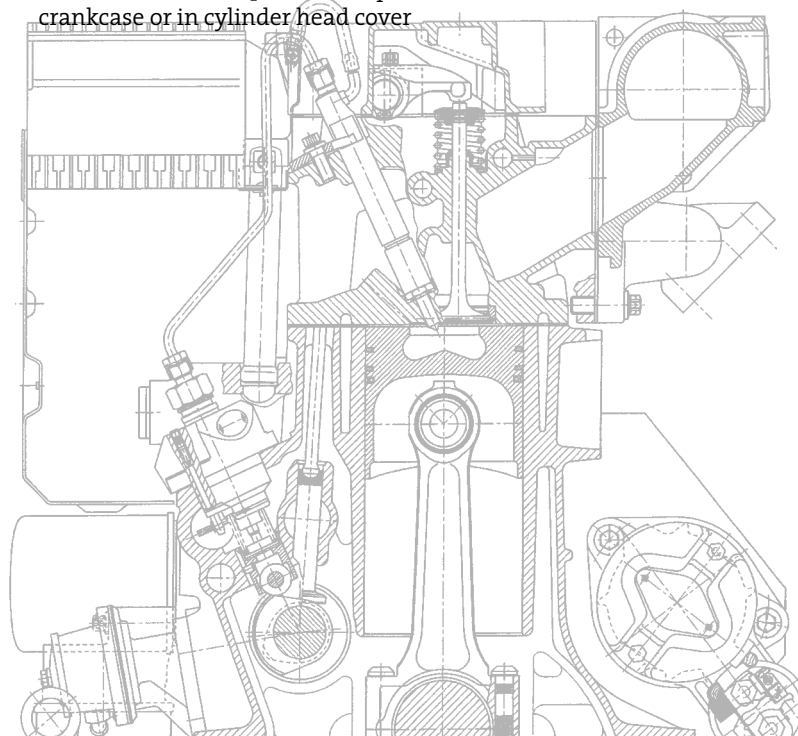

## ► Technical data

Engine type		F2L1011F	F3L1011F	F4L1011F	BF4L1011FT	BF4L1011F
Number of cylinders		2	3	4	4	4
Bore/stroke	mm	91/105	91/105	91/105	91/105	91/105
Displacement	l	1.37	2.05	2.73	2.73	2.73
Compression ratio		18.5	18.5	18.5	17.0	17.0
Max. rated speed	min <sup>-1</sup>	3300	3300	3300	2500	3000
Mean piston speed	m/s	11.6	11.6	11.6	10.5	10.5
<b>Power ratings for construction equipment engines<sup>9)</sup></b>						
Power ratings for automotive and industrial engines <sup>2)</sup>						
	kW	22.0	33.0	44.0	46.0	55.5
at speed	min <sup>-1</sup>	3000	3000	3000	2500	2800
Mean effective pressure	bar	6.44	6.44	6.44	8.07	8.71
Power ratings for continuous operation <sup>3)</sup>						
	kW	21.0	31.0	42.0	-	53.0
at speed	min <sup>-1</sup>	3000	3000	3000	-	3000
Mean effective pressure	bar	6.15	6.05	6.15	-	8.32
Max. torque	Nm	80.5	121.0	161.0	199.0	218.0
at speed	min <sup>-1</sup>	1800	1800	1800	1800	1800
Minimum idle speed	min <sup>-1</sup>	900	900	900	900	900
Specific fuel consumption <sup>4)</sup>	g/kWh	233	223	220	209	209
Weight to DIN 70020, Part 7A <sup>5)</sup>	kg	167	208	249	256	256

## ► Dimensions

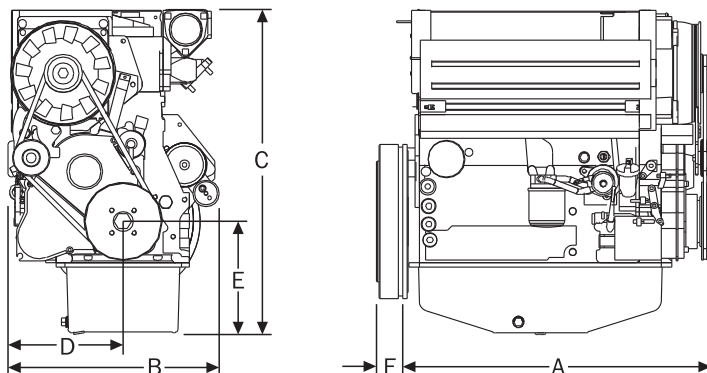

Motor		A	B	C*	D	E*	F
F2L1011F	mm	407	451	683	243	225	80
F3L1011F	mm	519	451	678	243	220	80
F4L1011F	mm	630	451	703	243	245	80
BF4L1011F/T	mm	630	495	703	243	245	80

## ► Model designation

BF 4 L 1011 FT

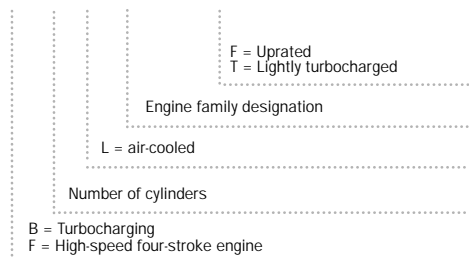

- 1) Power ratings at flywheel net, including integrated cooling system.
- 2) For intermittent operation to ISO 3046-1/ISO 1585.
- 3) Power ratings to ISO 3046-1 (ICFN).
- 4) At optimal operating point. Specific fuel consumption based on diesel fuel with a specific gravity of 0.835 kg/dm<sup>3</sup> at 15°C.
- 5) Including integrated cooling system, dry weight.

\* With standard oil pan.

The values given in this data sheet are for information purposes only and not binding. The information given in the offer is decisive.

## ► Standard engines

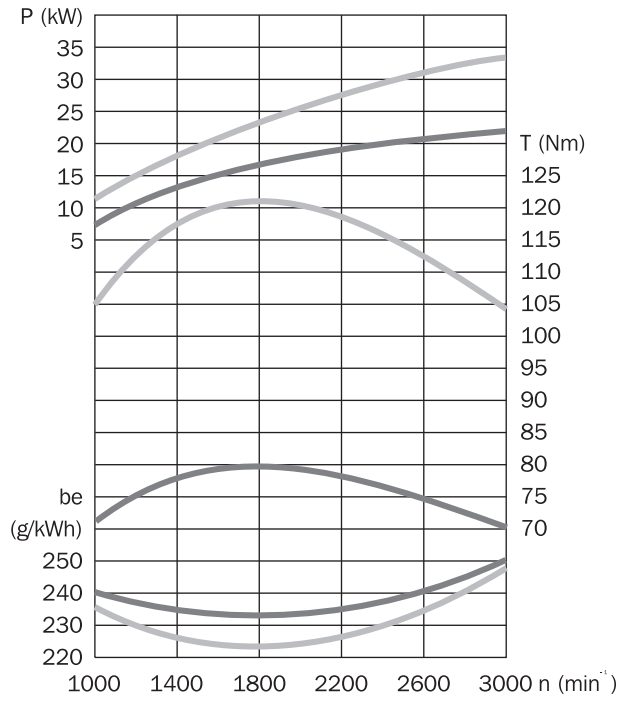

► F2L1011F

► F3L1011F

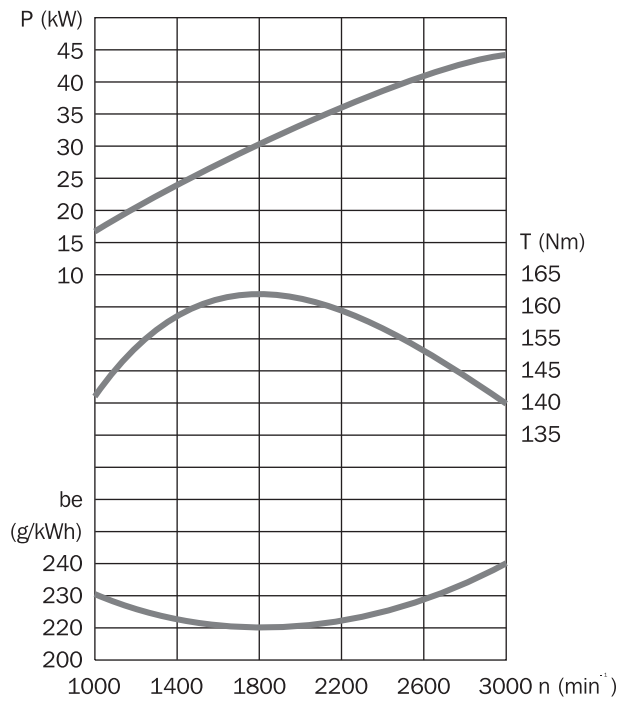

► F4L1011F

## ► Standard engines

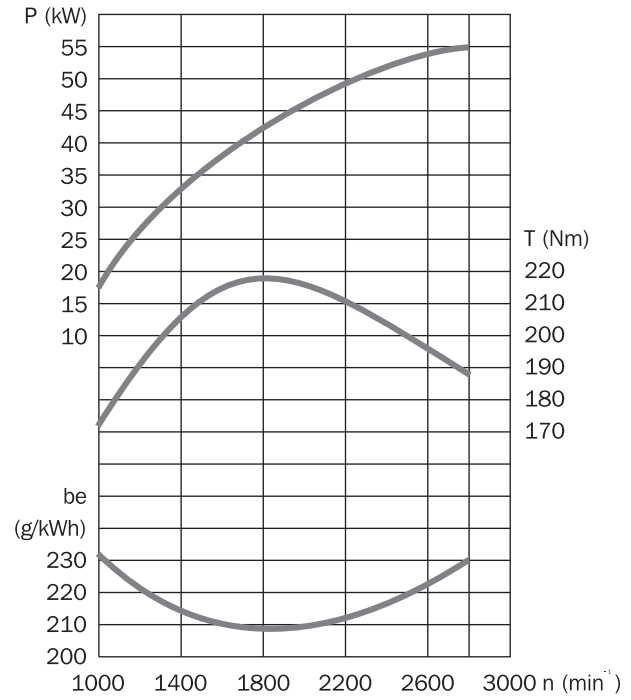

► BF4L1011F

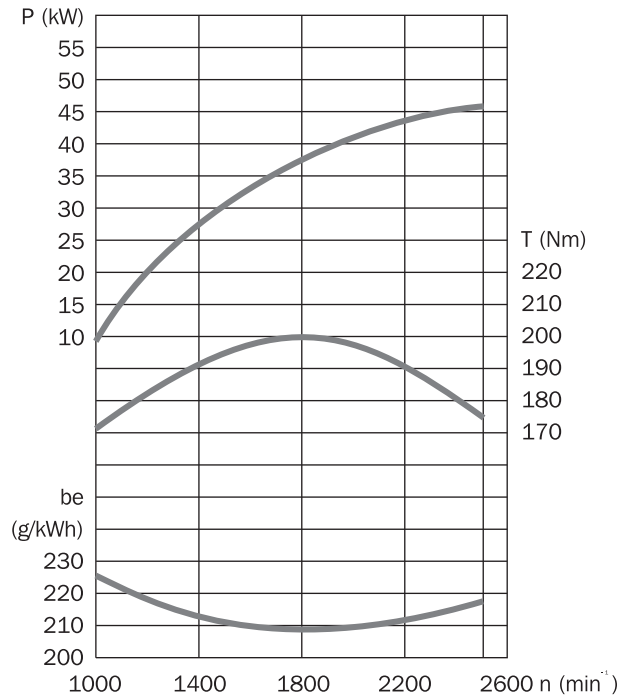

► BF4L1011FT



**Knowing it's DEUTZ.**

**DEUTZ AG**

Deutz-Mülheimer Str. 147-149

D-51057 Köln

Telephone: ++ 49 (0) 2 21-8 22 - 25 10

Fax: ++ 49 (0) 2 21-8 22 - 25 29

Internet: <http://www.deutz.de>