

# TCD 2015

The Agricultural Engine. 240–500 kW | 321.8–670.5 hp at 1900/2100 rpm

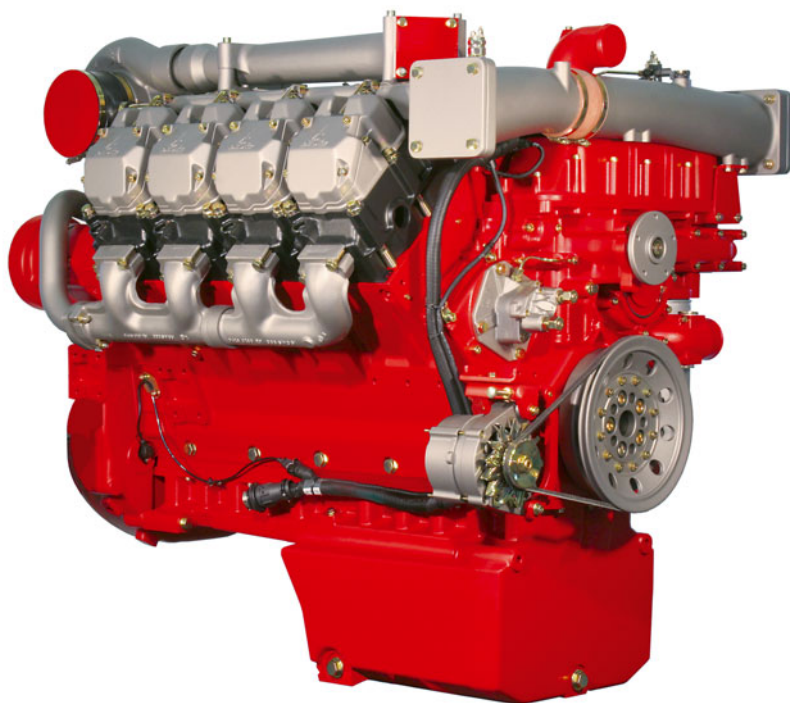

The engine company.



# Your benefits

- High equipment performance, availability and reliability thanks to the use of tried, tested and proven technology with high power density.
- The modern injection system ensures low fuel consumption and therefore high cost-effectiveness.
- Low noise emissions, high running smoothness and durability are the result of tried, tested and proven technology.
- The compact 2015 engine saves installation space and therefore reduces your installation costs.
- The 2015 series complies with 2004/26/EU level III A emission standards and EPA TIER III for mobile working machines.

# Characteristics

V engine with 90° angle, turbocharging and charge air cooling, four-valve technology | Extremely compact and powerful with high power density | Electronic injection system controlled via solenoid valves | Tried, tested and proven technology, equipped with acoustically optimised components

Engine model		TCD 2015 V6	TCD 2015 V8
Number of cylinders		6	8
Bore/stroke	mm   inch	132/145   5.2/5.7	132/145   5.2/5.7
Swept volume	l   cu inch	11.91   726.8	15.9   970.3
Rated speed	rpm	2100	2100
Minimum idle speed	rpm	600	600
Mean piston speed	m/s   ft/sec	10.15   33.3	10.15   33.3

## Performance for construction machine engines

Engine speed	rpm	1900	1900
Output <sup>1)</sup>	kW   hp	360   483	500   670.5
At mean, effective pressure	bar   lb/inch	17.2   249.5	19.9   288.6
Max. torque	Nm   lb/ft	2080   1535	2890   2133
At engine speed	rpm	1300	1400
Engine speed	rpm	2100	2100
Output <sup>1)</sup>	kW   hp	360   483	500   670.5
At mean, effective pressure	bar   lb/inch	19.1   277	18.0   261
Max. torque	Nm   lb/ft	2080   1535	2890   2133
At engine speed	rpm	1300	1400
Specific fuel consumption <sup>2)</sup>	g/kWh   lb/hp-hr	202   0.33	208   0.34
Weight acc. to DIN 70020, Part 7A <sup>3)</sup>	kg   lb	850   1874	1160   2558

## Dimensions

in mm   inch	TCD 2015 V6	TCD 2015 V8
A	814   31.7	1044   40.7
B	462   18.0	462   18.0
C	1150   44.9	1150   44.9
D	665   25.9	690   26.9
E	940   36.7	940   36.7
F	143   5.6	143   5.6
G	200   7.8	159   6.2

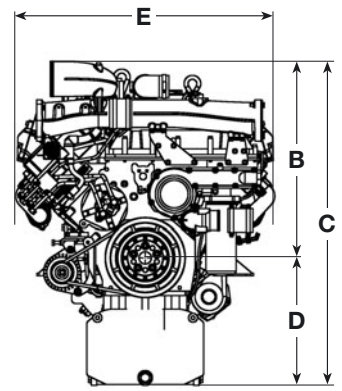
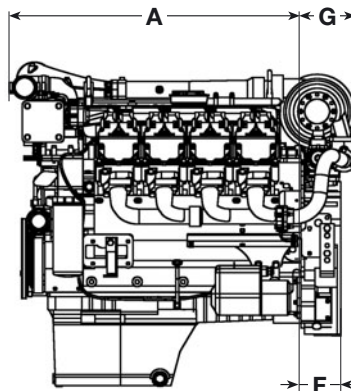

1) Output according to ISO 14396 (IFN), without deduction of fan output. The IFN output is net brake fuel stop power, which is available at the flywheel under standard reference conditions. In this case, all important, dependent auxiliary equipment is driven by the engine.

2) At the optimal point, exhaust emissions in accordance with level III A. Use of diesel fuel with a density of 0.835 kg/dm<sup>3</sup> at 15 °C (6.96 lb/US gallon at 60 °F).

3) Without starter/alternator, radiator and fluids, but with flywheel and flywheel housing.

The specifications in this data sheet are for information purposes only, and are not binding values. The specifications in the tender are authoritative